

| REV | DESCRIPTION | DRAWN | DATE |
|-----|-------------|-------|------|
|     |             |       |      |
|     |             |       |      |

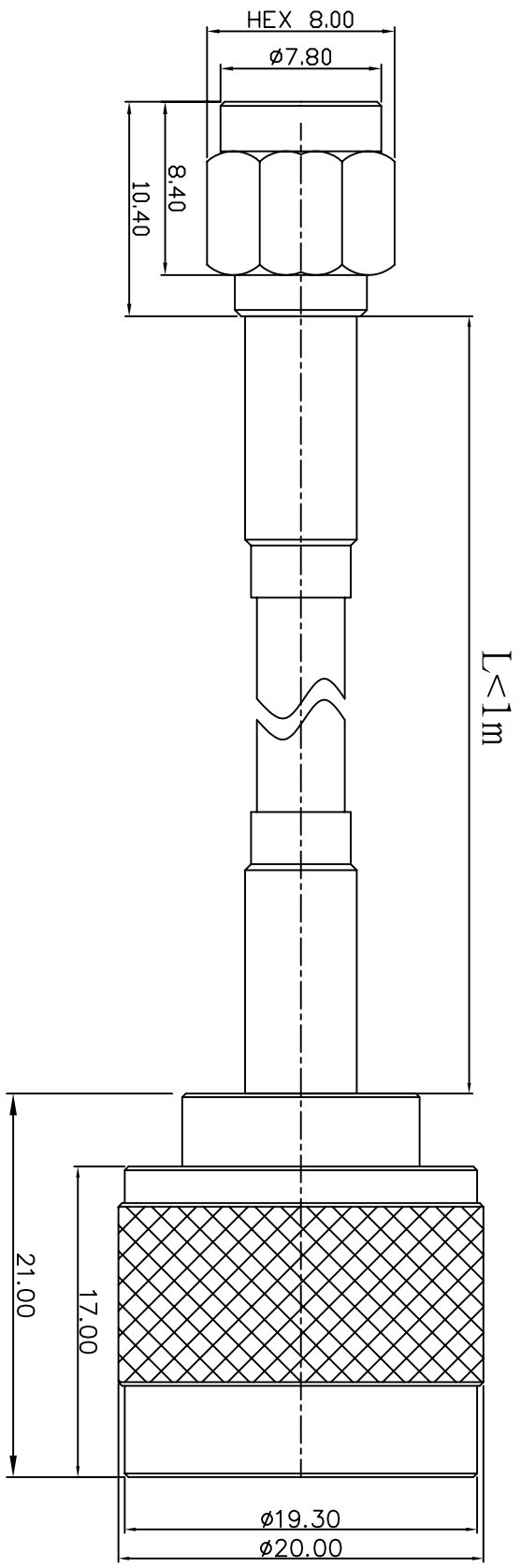

| NO | Description      | Qty | Material | Finish |
|----|------------------|-----|----------|--------|
| 3  | N-1101-6-F2-TGN  | 1   | BRASS    | NICKEL |
| 2  | LLC200/RG58      | 1   |          |        |
| 1  | SMA-1001-5-F-TGG | 1   | BRASS    | GOLD   |

|  |     |                       |    |
|--|-----|-----------------------|----|
| UNLESS OTHERWISE SPECIFIED   |     | *MAJOR DIMENSION      |    |
| 1 REMOVE ALL BURRS   |     | UNLESS OTHERWISE      |    |
| 2 BREAK ALL CORNERS & EDGES CO.15 MAX.                               |     | NOTED TOLERANCES      |    |
| 3 CHAMFER 1ST & LAST THREADS 45°                                     |     | 0.5-6=±0.2            |    |
| 4 DIAMETERS ON COMMON CENTERS TO BE CONCENTRIC WITHIN DIMENSIONS ARE |     | 6-30=±0.4             |    |
| 5 AFTER PLATING.   |     | 30-120=±0.6           |    |
| SCALE  | 3/1 | UNIT                  | MM |
| APPROVED   |     | DRAWN                 |    |
| CHECKED  |     | PEN                   |    |
| DRAWN DATE 04/09/29  |     | DRAWING NO.           |    |
|  |     | 10015/200/58/11016-1L |    |
|  |     | REV                   |    |
|  |     | A                     |    |

**華耀科技有限公司**  
 Hua Yao Technologies co.,Ltd

TITLE SMA1001-N1101

FILE NO. D:\DWG\SMA1001-N1101\10015/200/58/11016-1L